

Quick Start Guide

Electrically Heated Chamber Furnaces

N ... E(L)(R)

M01.1038K ENGLISCH

Original instructions

■ Made
■ in
■ Germany

www.nabertherm.com

Copyright

© Copyright by
Nabertherm GmbH
Bahnhofstrasse 20
28865 Lilienthal
Federal Republic of Germany

Reg: M01.1038K ENGLISCH
Rev: 2023-04

No responsibility is accepted for the correctness of this information. We reserve the right to make technical alterations.

1 Foreword

Congratulations on choosing a Nabertherm kiln. The product meets the highest standards of craftsmanship and is the result of many years of experience and consistent further development. This operating instructions summary will help you get to know your Nabertherm kiln. Remember that it is a short version of the operating instructions to give you an initial idea of the functions and features. Please read the operating instructions carefully before using your Nabertherm kiln for the first time.

You can obtain the operating instructions for the kiln via the following link or by scanning this QR code: Apps to scan QR codes can be downloaded from the corresponding sources (app stores).



<https://nabertherm.com/en/downloads/instructions>

Keep a printed or stored version for later use. You may also request a printed version of the operating instructions. Please contact us and state the kiln model and serial number (see type plate).

2 More information and tutorials



<https://nabertherm.com/de/downloads/video-tutorials>

These documents are intended only for buyers of our products and may not be copied or disclosed to third parties without our written consent.

(Law governing copyright and associated protective rights, German Copyright Law from Sept. 9, 1965)

Nabertherm GmbH owns all rights to drawings, other documents and authorizations, also in case of applications for protective rights.









3 Defined Application

Kilns in the NE series are electrically heated chamber kilns for firing ceramics and for glass or porcelain painting. The ideal working temperature is between 900°C and 1200°C. Do not place any materials that contain or emit flammable substances in the kiln.

This kiln may be used by children aged 8 years and above and by persons with reduced physical, sensory or mental capabilities or lack of experience and knowledge, provided they are supervised or have received instructions in using the kiln safely and they understand the hazards involved.

4 Safety precautions

Below is a list of safety precautions in the highest danger level, which, if not observed, may result in serious personal injury. A complete overview of all safety precautions can be found in the kiln operating instructions. Please read the operating instructions before initial start-up and use.

 	<p>Danger of electric shock Risk of fatal injury</p> <p>Work on the electrical equipment may be performed only by qualified electricians or by specialists authorized by Nabertherm.</p> <p>Before starting work, disconnect the plug</p> <p>The device must not get wet</p> <p>Do not insert objects into openings in the kiln housing, exhaust holes or cooling slits of the switchgear or kiln.</p>
	<p>Risk of fire, danger to health Risk of fatal injury</p> <p>Observe the installation conditions</p> <p>Adequate ventilation must be ensured at the installation location to remove exhaust heat and exhaust gases.</p>
	<p>Do not open when hot</p> <p>Opening the kiln when it is hot above 200 °C (392 °F) can cause burns.</p> <p>No liability is assumed for damage to ware or kiln.</p>
 	<p>For all kiln systems</p> <p>These kiln systems have no safety technology for processes in which flammable mixtures can form</p> <p>Operation with explosive gases or mixtures or the formation of explosive gases or mixtures during the process is not permitted.</p> <p>Do NOT place any potentially explosive dusts or solvent mixtures inside the device.</p> <p>Do NOT operate the device in areas where there is a risk of explosion.</p>
	<p>Bypass connection/exhaust duct, lid and kiln housing are hot when the kiln is in operation. Risk of burning.</p> <p>Bypass connection/exhaust duct, lid and housing must NOT be touched during operation.</p>
	<p>Risk of fire if using an extension cable Risk of fatal injury</p> <p>For all kiln models with a plug-in connection, ensure that the distance between the circuit breaker and the power socket to which the kiln is connected is as short as possible.</p> <p>NO power board or extension cable is used between the power socket and the kiln.</p>

5 Kiln components

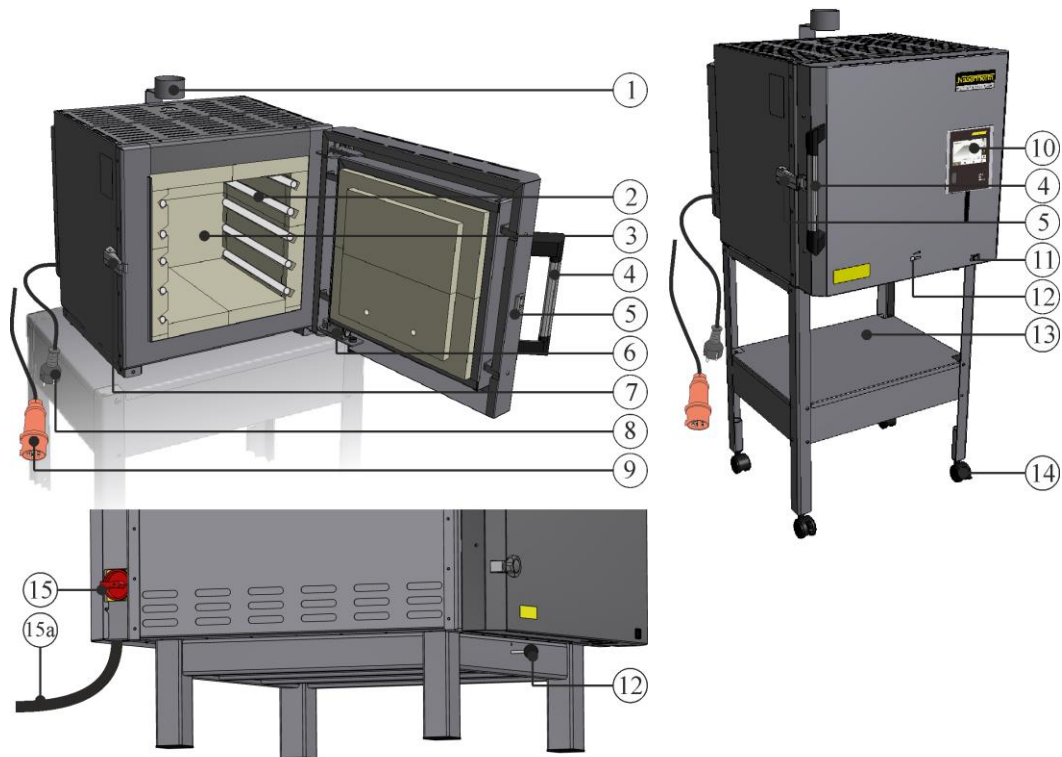

No.	Name	No.	Name
1	Bypass connection	9	CEE plug (up to 3600 watts, max. 32 A)
2	Heating elements, protected in grooves	10	Controller (depending on design)
3	Kiln chamber	11	Protective device switch with integrated fuse (for switching the kiln on/off)
4	Handle	12	Fresh-air inlet (infinitely adjustable)
5	Swing door	13	Base frame (accessory):
6	Door contact switch	14	Transport casters as accessories
7	Adjustable door lock	15	Main switch (from 32 A)
8	Power plug (to 3600 watts) with snap-in coupling	15a	Fixed connection with 3 m cable without plug (from 32 A)

6 Transporting the kiln



Note

Wear protective gloves when installing the kiln.
The kiln should be transported by at least two people.

- When the kiln is delivered, check the transport packaging for possible damage. Remove straps from the transportation packaging.
- Compare the delivered items with the delivery note and the purchase order documents.
- Carefully remove the cardboard box or wooden crate. The pallet contains a packaging unit with accessories (e.g., power cable, bypass connection, ceramic shelves).
- To carry the kiln, place your hands at the sides beneath it and make sure that you have a firm grip. Lift the kiln from the pallet and carefully lower it at the location where it is to be installed.
- If the kiln is to be transported with a pallet truck, we strongly recommend that you use the wooden transport frame. If the fork of the pallet truck is positioned incorrectly, this may damage the kiln.
- Completely remove the packaging material in and on the kiln as well as beneath the exhaust air flap. All packaging material can be recycled.

7 Requirements for the installation location

When choosing a place to install the kiln, make sure that the room is dry. Temperatures should be between +5 °C and +40 °C, with maximum 80% humidity. The surface (floor or bench) where the kiln is to be installed must be level to enable the kiln to stand upright. Place the kiln on a non-flammable surface. The load-bearing capacity of the bench must be suitable to take the weight of the kiln plus accessories.

Flammable materials must be kept at least 1 m from the kiln on all sides. In some cases, the distance must be greater in order due to local conditions. The minimum distance between the kiln and non-flammable materials may be reduced to 0.2 m at the sides. If the charge emits gases or vapors, ensure adequate ventilation at the installation site and/or a suitable exhaust gas venting system. If required, the customer must provide a suitable extraction system for exhaust air.

8 Assembly, Installation, and Connection

Assembling the base frame (N 40 E– N 100 E)

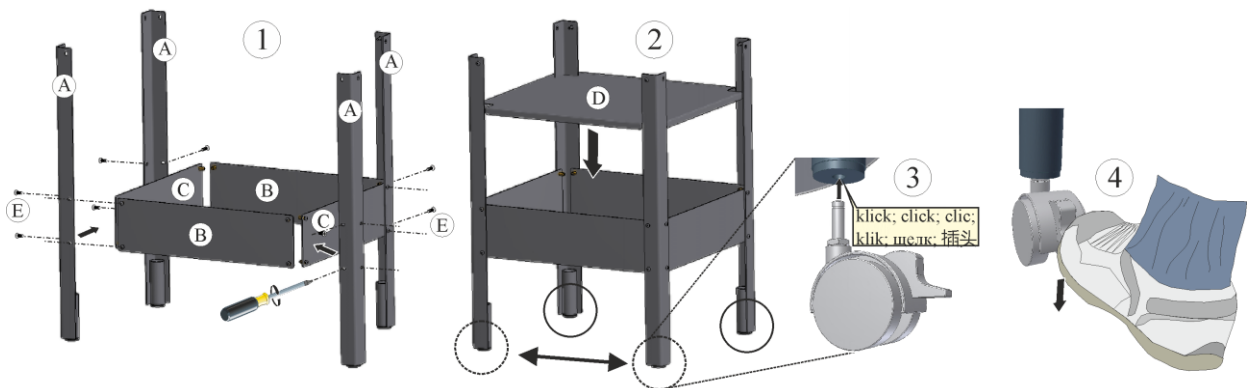

As shown in (1) and (2), use a screwdriver to assemble the individual parts of the base frame and then attach the transport casters (3) (if applicable). Engage the locking brake facing the kiln door to stop the frame rolling away (4).

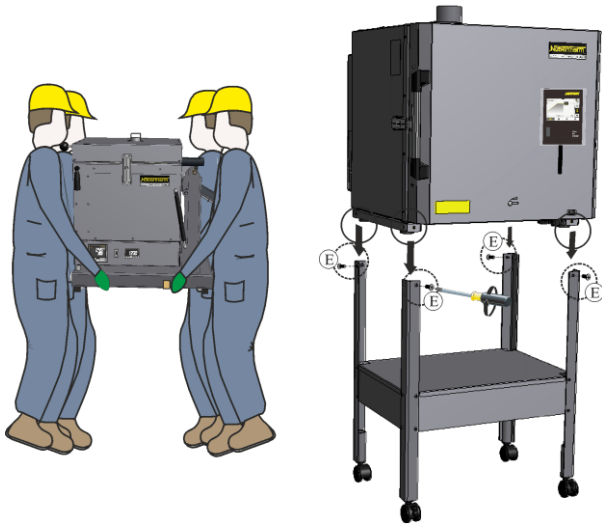

With at least two people, carefully place the kiln on the frame and make sure that it sits properly. Then screw the kiln onto the frame at the positions illustrated (E).

Assembling the base frame (N 140 E – N 280 E)

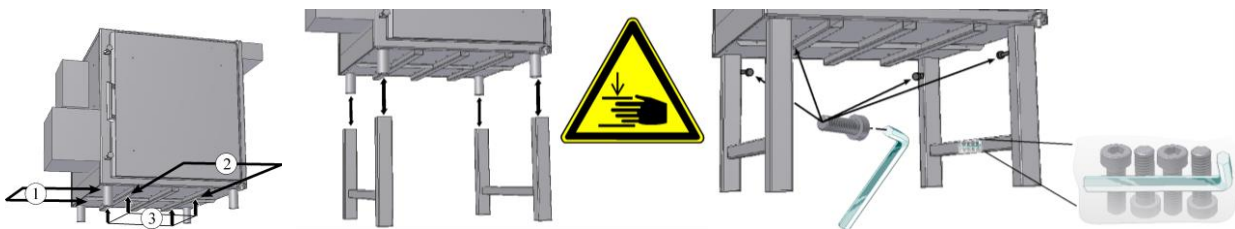

Use a suitable forklift truck to lift the kiln.

Slide the forks of the forklift truck completely beneath the kiln floor either from the side (1) or from the front (2). Only the floor profiles (3) of the kiln floor may rest on the forks of the forklift truck. Pay attention to attachments, piping or cable ducts. Lift the kiln smoothly.

Carefully lower the kiln onto the base frame and make sure that it sits securely in place. Then secure the frame, using the four screws that are supplied.

Installing the bypass connection

Mount the bypass connection (model-related) that is part of the delivery on the kiln.

- At the bypass connection position there are screws (1) to assemble the connection; these must be loosened beforehand.
- Place the bypass connection (2) with the screws loosened at the correct position on the kiln and fasten it with suitable tools.

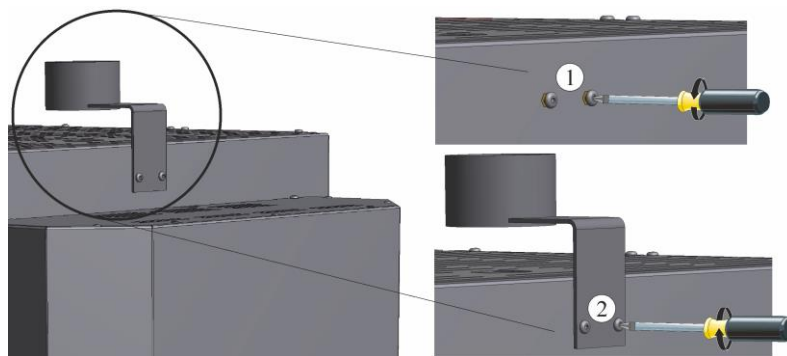

Placing the controller in the holder on the kiln

Place the controller in the holder on the kiln. Make sure that the controller is placed correctly in the holder. If this is ignored, the controller may be damaged or destroyed. Nabertherm accepts no liability if the controller is not handled properly.

Installing the automatic air inlet flap

For instructions on how to install the automatic air inlet flap and the air inlet flap with fan, please refer to the complete operating instructions (“Assembly, Installation and Connection”).

9 Venting Exhaust Fumes

When ceramics are fired, depending on the quality of the clay and/or glaze, they can emit gases and vapors that are harmful to health. It is therefore necessary to make sure that the exhaust gases emitted from the exhaust air opening are directed outdoors in a suitable manner (ventilate the working area). If adequate ventilation cannot be ensured at the working area, the “exhaust gases” must be removed via suitable heat-resistant ducting. For detailed information and detailed requirements for exhaust ducting, refer to the kiln operating instructions.

10 Connecting the kiln to the power supply



Nabertherm MORE THAN HEAT 30-3000 °C		
Nabertherm GmbH Bahnhofstr. 20, 28865 Lilienthal/Bremen, Germany Tel +49 (04298) 922-0, Fax +49 (04298) 922-129 contact@nabertherm.de		
www.nabertherm.com		
N 70 E/R	SN 123456	2022
NEO2R2N-NE	1300 °C	 5,5 kW
-	400 V 3/N/PE~	-
50 Hz	13,8/0,0/13,8 A	5,5 kW
		

The fuse protection and the cross-section of the required power connection depend on local conditions, the length of the cable and how it is installed. For this reason, the type of protection and how it should be installed must be decided by a qualified electrician.

- The power cable must not be damaged
- Do not place any objects on the power cable
- Lay the cable so that no one can stand on it or trip over it
- Power cables may be replaced only with similar, approved cables

Power cable with plug:

Insert the plug into a suitable electric socket with a separate power supply and fuse. Pay attention to the information on the type plate as regards voltage, supply type and max. power consumption. The distance between the kiln and the socket should be as short as possible. Do not use extension cables or power strips. Have an electrician check the building wiring and electric socket before connecting the kiln. With household electric plugs, a loose contact can cause burning.

The power plug must be accessible at all times when the kiln is operating so that it can be pulled out quickly in case of an emergency.

Power cable without plug:

Power cables that are supplied without a plug must be connected to the power supply by a qualified electrician. If the kiln is supplied with a plug, it must not be connected subsequently without a plug. The power cable must be a fixed connection in the control cabinet, either at the prepared terminals or, in models with a separate switchgear, directly at the main switch. When carrying out this work, pay attention to the information on the type plate as regards voltage, supply type and max. power consumption.

11 Initial Start-Up and Initial Heating

Before starting the kiln for the first time, allow it to acclimatize at its installation location for 24 hours.

When the kiln is put into operation, the following safety information must be observed to prevent serious injury and damage to property.

- Make sure that the instructions and information in the operating manual and the controller instructions are observed and followed.
- Before starting the kiln for the first time, make sure that all tools, parts that do not belong in the kiln and transportation securing equipment have been removed.
- Before you switch on the kiln, make sure that you know what to do in case of faults or emergencies.

Heat the kiln to dry out the insulation and to get a protective oxide coating on the heating elements. **The life of the heating elements is dependent on obtaining a good oxide coating.** There may be some unpleasant odors while the kiln is heating. This is due to binder being emitted from the insulation material. It is advisable to ventilate the room in which the kiln is located well during the first heating phase.



1. Half open the adjustable air inlet
2. Close the kiln door
3. Switch on the kiln/controller at the power switch
4. Run the pre-set program "Program 01" (without kiln furniture)
5. When the program ends, allow the kiln to cool naturally

The insulation materials and furniture have natural residual moisture.

During the first firings, condensation may accumulate and drip from the housing.

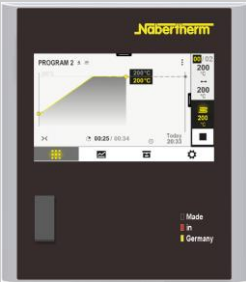

12 Operation

Switch on the controller			
	Procedure	Display	Comments
	Switch on the power switch		Set the power switch to "I". (Power switch type varies according to design/kiln model)
	The kiln status is displayed. After a few seconds, the temperature is displayed. The first time you switch on the kiln, a wizard is displayed that enables you to enter some basic settings, such as language.		When the temperature is shown on the controller, the controller is ready for operation.



Note

See the separate operating instructions for a description of how to enter temperatures and times and to "start" the furnace.

13 What to Do in Case of Emergency

In case of unexpected events in the kiln (e.g., a lot of smoke, odors or fire), switch the kiln off immediately by disconnecting the power plug and keep the door closed. Wait until the kiln has cooled naturally to room temperature. **The electric socket must be accessible at all times when the kiln is operating.**

Accordingly, switch off a kiln with fixed connection **immediately at the main switch** (position "O/OFF") and keep the door closed. Wait until the kiln has cooled naturally to room temperature.

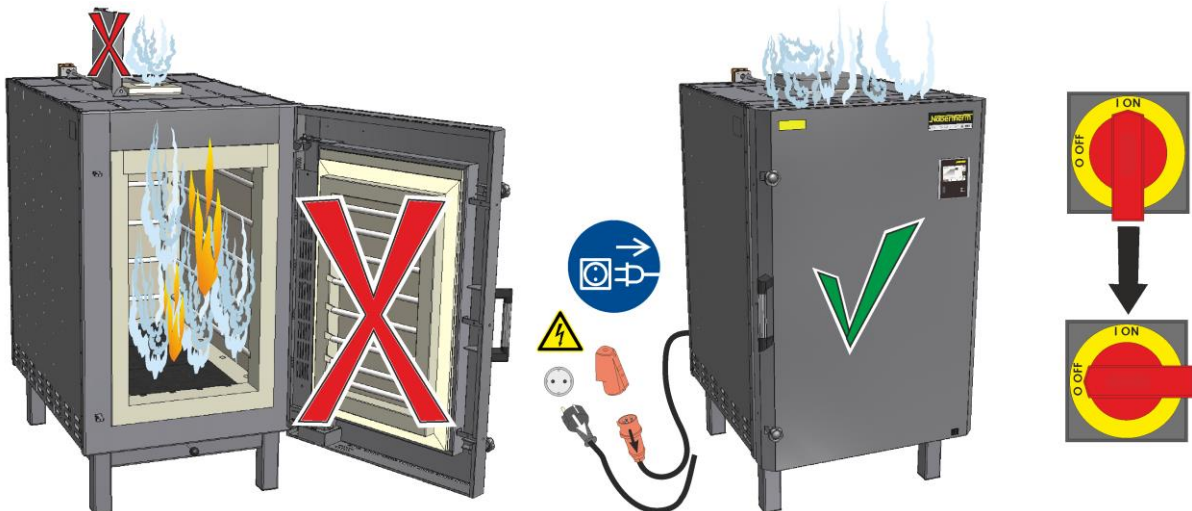

14 General Operation and Loading the Furnace

Operate the system only when all protective equipment and safety-related devices are present and functioning. Place only materials and substances whose properties are known in the kiln. Before starting the firing, clear the area around the kiln.

Large quantities of material in the kiln can substantially lengthen the heating-up time. If the material in the kiln is packed densely, this can affect the temperature distribution.

When the kiln is being loaded, be sure to avoid concentrated loads (maximum 10 kg/dm²). Do not exceed the maximum charge weight. The load limit of the kiln floor is approx. 50% of the kiln volume in kg.

To ensure that the heat is removed from the floor heating chamber, do not place the bottom shelf directly on the floor. A minimum gap of 5 cm is recommended.

Depending on the required temperature distribution, position the charge at a suitable distance from the walls, floor, door and roof.

Pre-set programs

Several programs are pre-set on the controller and can be started directly. The example programs for ceramic applications are stored in the factory in programs "P02 - P05".

- For example, for a biscuit firing (950°C), choose the stored program "P02" from the overview.
- The program is now loaded and can be started.
- Acknowledge the subsequent security prompt with "Yes".

Do not open the kiln when it is hot (>200 °C). The housing or its cladding may discolor, but this does not affect the functions of the kiln. We recommend that you leave the charge in the kiln until it is completely cooled.

15 Cleaning products

To clean the furnace, it is important that the power plug is pulled out and that the furnace has cooled completely. Pay attention to the labeling and information on the cleaning product packaging.

Use commercial cleaning products that are either water-based or non-flammable and free of any solvents to clean the housing. Use a vacuum cleaner for the interior.

Wipe the surface with a damp, lint-free cloth. You may also use the following cleaning products:

Component and position	Cleaning product
Outer surfaces (frame)*	Use commercial cleaning products that are either water-based or non-flammable and free of any solvent*
Outer surfaces (stainless steel)	Stainless steel cleaner
Interior	Carefully clean with a vacuum cleaner (pay attention to the heating elements)
Insulation materials	Carefully clean with a vacuum cleaner (pay attention to the heating elements)
Door seal (if applicable)	Use commercial cleaning products that are either water-based or non-flammable and free of any solvent*
Instrument panel	Wipe the surface with a damp, lint-free cloth (e.g., glass cleaner)

*You must ensure that the cleaning product does not damage the water-soluble, environmentally safe paint (test the product on an interior, concealed area).

Clean quickly to protect the surfaces. Remove the cleaning product completely from the surfaces by wiping them with a damp, lint-free cloth.

